



IHI Connectors ® TORK KRIMP ® PATENTED “NO PRE-CRIMP” FERRULE METHOD



“Save with the TORK KRIMP ® SMILE 😊!”

Use a ferrule in a mechanical connector without pre-crimping.
License and Patent information below.

US Patent no. 10630005 April 21, 2020

www.IHIConnectors.com/patent.html

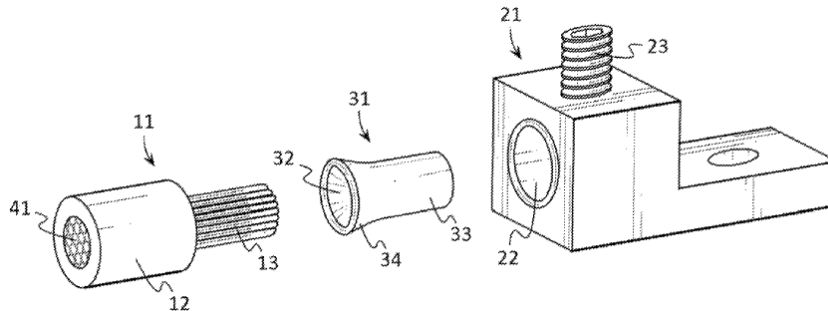

© 2020 IHI

1. ADVANTAGES and ECONOMIC PAYBACK:

- No pre-crimping tools needed since the screw type connector is the crimp tool.
- No crimping time lost in pre-crimping the ferrule to the wire.
- Standard generic ferrules may be used which are very low cost.
- Ferrules do not need to be Agency rated for any particular OEM crimp tools.
- Perfect for controlling fine stranded flex wire.
- Able to pass UL486A-B C22.2 No. 65 testing connector rating standard at 90C ratings (see list of parts below).
- Enables larger wire sizes to fit into any substantially round hole connector compared with pre-crimped ferrules, since pre-crimped ferrules are like “a square peg in a round hole”.
- Manages fine stranded wire by controlling the strands and strand breakage.
- Makes insertion of a fine stranded wire into a wire hole easier with flared entrance.
- Connector maintains all non-ferrule ratings for direct wire use at any time since choice to use the ferrule occurs at the user site.
- Factory or field installation applicable.
- Ferrules used only when required for maximum flexibility in wiring options
- On demand method may be used only when needed with no OEM custom parts required.
- Agency ratings available using this patented method with UL and CSA.

2. ABSTRACT

(57)

ABSTRACT

An electrical coupling method for coupling an electrical conductor to a connector may provide for the elimination of pre-crimping, crimp tooling and pre-crimp UL testing certifications that go with it, and by testing standard generic ferrules in the said Dual Rated connectors, and by use of a UL approved instruction sheet, for the user to utilize generic ferrules. The may include the steps of: inserting one or more electrical conductors and an uncrimped ferrule into a connector aperture of an electrical connector, the one or more electrical conductors and uncrimped ferrule being uncoupled to each other prior to insertion into the connector aperture; and screwing a clamping screw so that preferably the clamping screw simultaneously (i) crimps the uncrimped ferrule to the first electrical conductor and (ii) secures the ferrule and first electrical conductor to the electrical connector within the connector aperture.

3. SCOPE SUMMARY (see patent for full legal scope)

Any wire connector, which uses a screw to bind the wire(s) or conductor(s), where it is desired to use a wire size appropriate ferrule, with no pre-crimping of the ferrule, but performing “self-crimping” of the wire or conductor by clamping them at the same time, utilizing the same screw as the wire or conductor would otherwise be clamped.

3. LICENSING: For licensing information please contact: critley@ihinet.com

Any connector user or manufacturer who wishes to use this patented feature may make a request to IHI Connectors® for an appropriate license.



IHI connector part numbers that carry the TORK KRIMP® registered trade mark are sold with the license fee prepaid for use of this patent on the specific listed catalog number parts made and listed by IHI under the TORK KRIMP® trademark.

A list of parts with the TORK KRIMP[®] patented feature pre-licensed with the purchase of the parts is maintained on the web sites along with the TORK KRIMP[®] trademark and logo.

4. CONDUCTOR AND FERRULE RANGE:

What, in brief, is covered by the patent? (guide only – see the patent for the only legal wording)

- Conductor, and ferrule sizes from 0.25mm² to 400mm² for single port and dual /multi-port connectors.
- Use of bare and insulated ferrules and generic or agency rated ferrules which meet the appropriate ferrule area to conductor aperture area ratio defined in the patent.
- Use of single or twin conductor ferrules which meet the appropriate ferrule area to conductor aperture area ratios defined in the patent.
- Use of the connector screw to crimp the un-crimped ferrule onto the conductor while in the connector using torques that provide the desired pull out forces expressed in Newtons within the appropriate range formulas defined in the patent.

5. What is not covered by the patent:

- Copper shim wraps where metal, often copper shim stock, is wrapped around the conductor prior to insertion.
- Custom size OEM ferrules that are pre fitted to the OEM connector, typically to couple a wide range of conductor sizes in one pre-ferruled connector.

“ Save with the TORK KRIMP[®] SMILE  ! ”

PARTIAL LIST OF PARTS WHICH UTILIZE THIS PATENT WHILE HAVING EXISTING AGENCY RATINGS THAT INCORPORATE THE PATENTED METHOD

Single Barrel Lugs

S2
S2-HEX
S2-171
S2-171-HEX
S2-171-13627
S2-TP
S2-TP-HEX

Double Barrel Lugs

2S2
2S2-HEX

Splicer Reducers

P2
P2-HEX

Multi Barrel Lugs

S2-NB-2
S2-NB-2-HEX
4S2-HEX
4S2-N-21-2
6S2-HEX